

- 1 input
- 1 NO / NC output
- battery supply
- IP65 housing
- IP68, EX probes

The battery-powered alarm module is used to control the level of the sludge layer, oily substances, fat, petroleum substances and tank overflow.

⚠ To avoid problems in operating the unit, it is recommended to read this manual thoroughly before using it. Do not interfere with construction or carry out repairs yourself. Maintenance or repair work should be carried out by qualified personnel (installer or company service). The manufacturer assumes no responsibility for any damage resulting from improper assembly, malfunction (device, software) or damage to the controller. When installing in places with a potentially explosive atmosphere, comply with the regulations in force in your country. When servicing, checking and repairing in explosive atmospheres, the national standards must be observed.

Description

The SQUEALER-1B controller is a modern, microprocessor battery-operated device, used for continuous monitoring of the status of one of the selected probes (MAX, OILER, SLUDO). The controller works in sleep mode, which is indicated by flashing green LED every few seconds. SQUEALER-1B energizes the sensor for 10s every 1h and performs the measurement. If the sensor detects a violation during the measurement or if there is a short or open condition, then the controller will wake up and start signaling the alarm. The controller can be woken up by pressing the key for 1s. If there is no violation of the sensor, the controller goes to sleep after 180s. When the sensor is turned off, the controller goes into sleep mode after approx. 15 seconds. If the battery voltage drops below 2.7V, the controller will signal 2 short beeps every 15 seconds. (in sleeping and waking up).

Front panel description

1. WAKE UP MODE

- OK - the LED is green - the probe is in the normal state
- ALARM - the LED shines alternately green and red, informing about the alarm
- FAILURE - the LED flashes red - indicating shorting / opening of the cable
- OFF - The LED is off when the sensor support is turned off (dipswitch 1 - off)

- Short press of the button during normal state - a test of diode, buzzer and relay operation is started

- Short press of the button during alarming - cancellation of the acoustic alarm signaling, LED and relay remains on

- Long press of the button during alarm (on request version) - cancellation of acoustic alarm signaling and return of the relay to the normal state

2. SLEEP MODE

OK - the LED flashes green every few seconds.

- A short press of the button wakes the controller for 180 seconds.

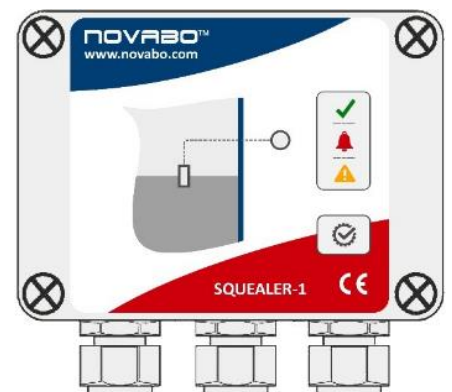

Cooperating Devices



MAX - optical probe for overflow or maximal level.



OILER - thickness measurement of fat, oil, mineral oil, organic, petroleum substances.



SLUDO - detecting the sediment layer in the separator or the maximum level



COUPLER-01 – hermetic coupling plug



NFIK-01 – set for mounting the probe



CABLE-5, CABLE-10 – sensor extension cable

Probes assembly

- Lower the sensor so that the measuring point is at a exceeding level.
- Attach the sensor cable to the mounting bracket NFIK.
- Use the COUPLER connector to lengthen the cable

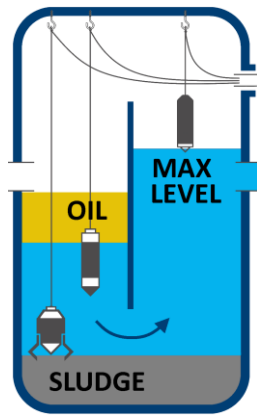

Controller description

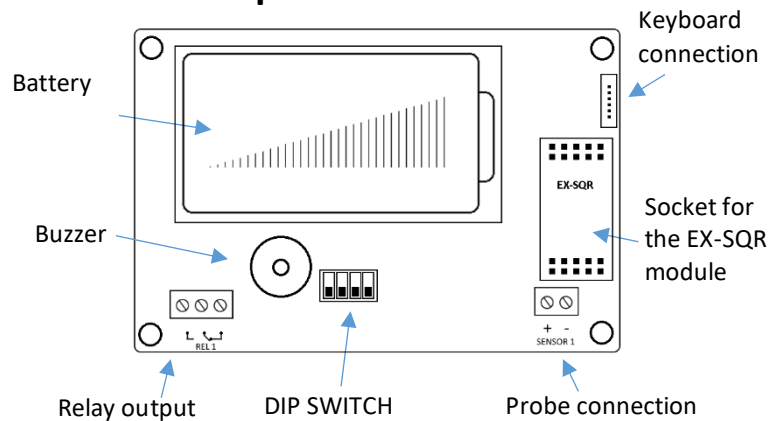

DIP SWITCH configuration

- DIP1** "ON" - SENSOR active - probe connected
"OFF" - SENSOR inactive - probe not connected
- DIP2** - not used
- DIP3** - not used
- DIP4** "ON" - inverted input logic SENSOR
"OFF" - normal logic of the SENSOR

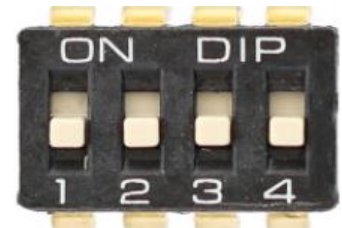

Technical Data

1 input, 1 relay output; LED diodes indicating normal state, failure and alarm; BUZER generating an audible alarm; RELAY - relay output NO / NC 0.5A / 125VAC; Power supply: 3.6V 19Ah battery

Battery life: 2-3 years; ambient temperature: -40 to + 60 ° C; mechanical strength: IK 07; housing dimensions (without glands) (H x W x D): 96 x 130 x 66 mm; cable glands: 2 x M12, cable diameter Ø 4.0-6.0 mm

Checks and inspections

The manufacturer recommends inspections of the entire system once every 6 months or during the emptying of the separator. During the inspection, clean the probe and check that it has no mechanical damage. Then, perform an operation test in cooperation with the SQUEALER controller.

NOVABO

tel.: +48/58-746-37-73

www.novabo.com , novabo@novabo.com

NOVABO™
measurement and automation